

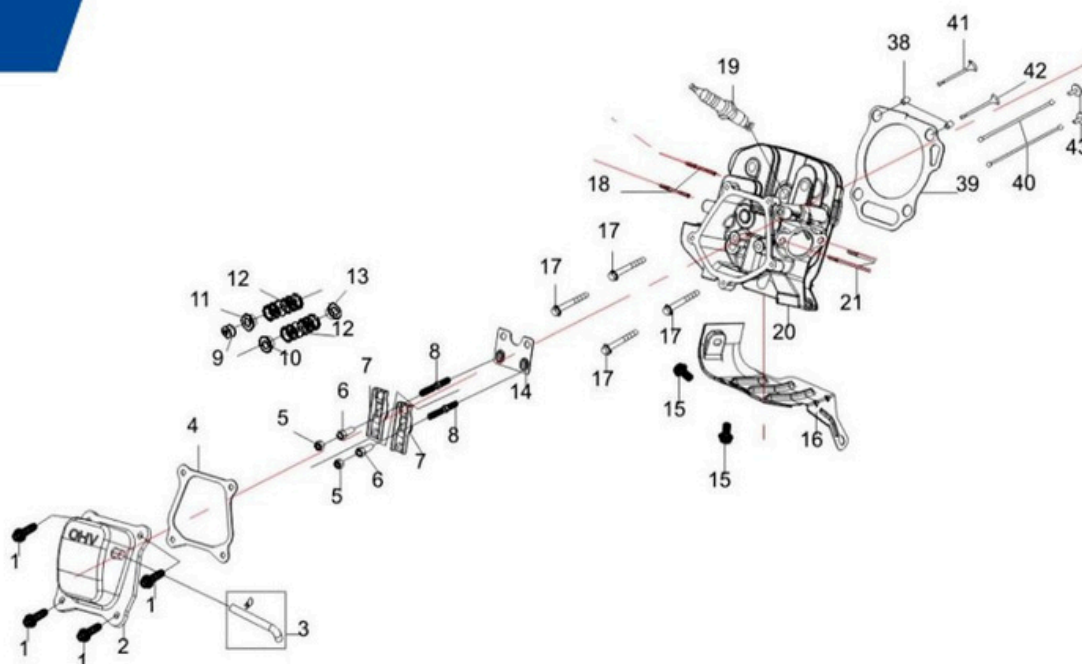

Manual de partes de Generador MPOWER 3500-X15



<https://serviconstructor.com.mx>



N°	PARTEN°	DESCRIPCIÓN	CANT
1	12220/168F	Bolt	4
2	12200/168F	cylinder head cover assy	1
3	11513/182F	air pipe	1
4	12212/168F	gasket	1
5	14314/168F	nut	2
6	14312/168F	seat pin	2
7	14311/168F	valve rocker	2
8	14313/168F	bolt	2
9	14416/168F	cap of valve	1
10	14413/198F-2	spring seat	1
11	14415/168F-2	spring seat	1
12	14414/168F	valve sping	2
13	14420/2GF-3	Valve stem oil seal	1
14	14220/168F	pusher guide	1
15	GB/T16674	bolt	2
16	19121/168F	lead wind cover	1
17	12118/168F	bolt, cyliner head cover	4
18	18214/168F	stud	2
19	27100/168F	spark plug	1
20	12100/168F-2	cyliner head assy	1
21	17218/2GF-3	stud	2

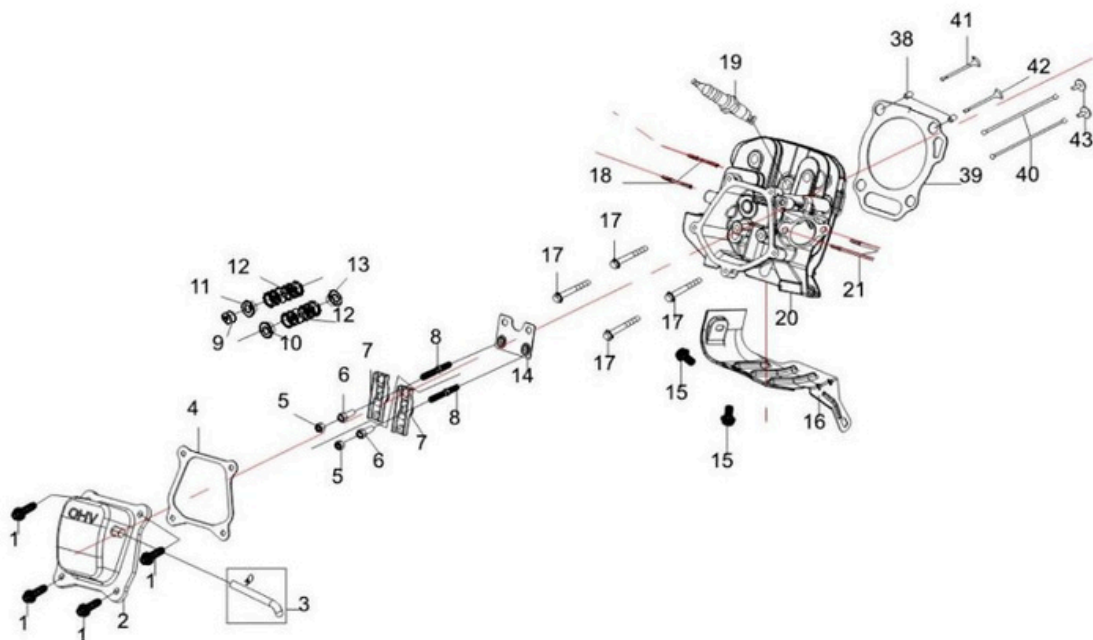

N°	PARTEN°	DESCRIPCIÓN	CANT
38	12117/168F	set pin	4
39	12120/170F	gasket,cylinder head	1
40	14210/168F	pusher guide	1
41	14412/168F-2	exhaust valve	1
42	14411/168F-2	intake valve	2
43	14315/168F-2	tappet	2

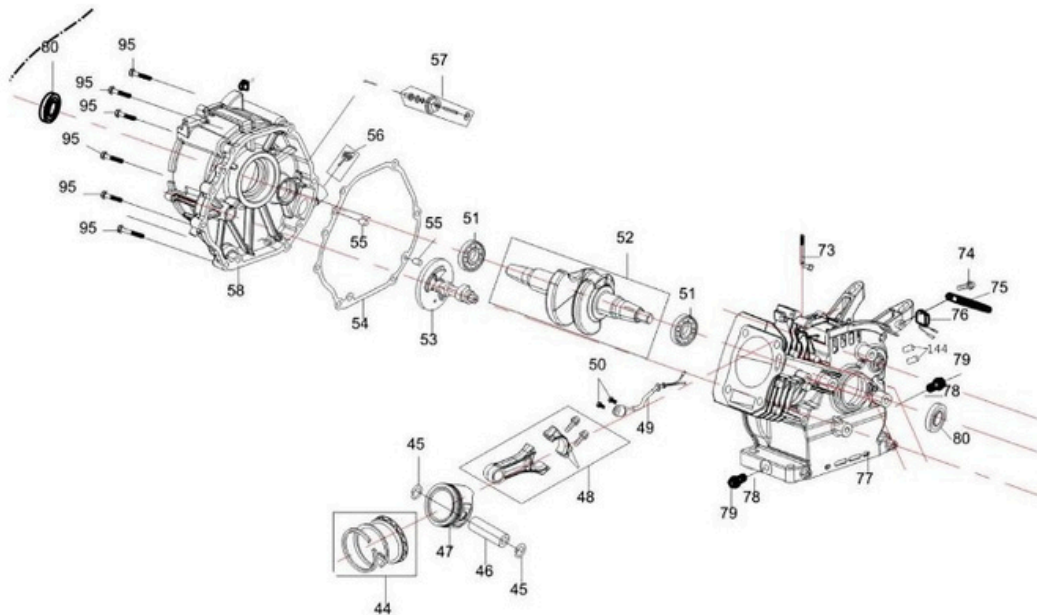

N°	PARTEN°	DESCRIPCIÓN	CANT
44	13400/170F	piston ring	1
45	13313/168F	piston pin washer	2
46	13312/168F	piston	1
47	13311/170F	piston	1
48	13120/168F	conneting rod	1
49	27400/168F	oil sensor assy	1
50	GB/T5789	bolt	2
51	GB/T276	bearing	2
52	13110/170F	crankshaft	1
53	14100/168F-2	camshaft	1
54	11114/168F	gasket, crankcase	1
55	11113/168F	set pin	2
56	15510/168F	dipstick	1
57	25100/168F	driven gear	1
58	11211/170F	crankcase cover assy	1

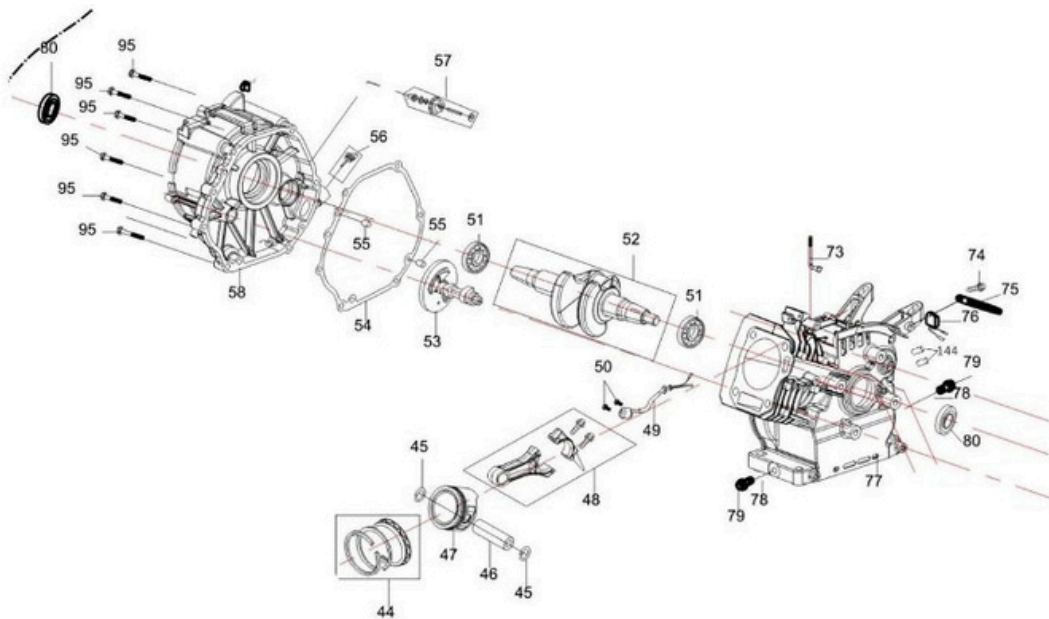

N°	PARTEN°	DESCRIPCIÓN	CANT
73	26111/168F	regulating sway bar	1
74	GB/T5789	bolt	1
75	19316/173F	clamp	1
76	27500/168F		1
77	11110/170F	crankcase assy	1
78	11116/168F	washer , drain bolt	2
79	11115/168F	drain bolt	2
80	11120/168F	seal , crankcase	1
95	12118/168F	bolt	6

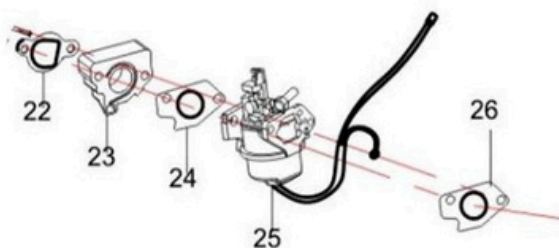
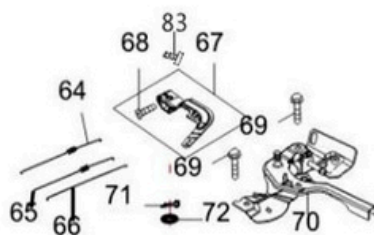

N°	PARTEN°	DESCRIPCIÓN	CANT
22	17219/168F	gasket, air intake	1
23	16120/168F	conneting block	1
24	16113/168F	gasket, carburetor	1
25	16100/2GF-3	carburetor assy	1
26	17113/168F	gasket, air cleaner	1
64	26117/168F	back spring	1
65	26118/168F	regulating spring	1
66	26115/168F	pulling rod	1
67	26114/168F	regulating arm	1
68	GB/T6177.1	nut	1
69	GB/T5789	bolt	2
70	26200/2GF-3	regulating frame	1
71	26112/168F	pin, regulating sway bar	1
72	26113/168F	washer, regulating sway bar	2
83	26116/168F	bolt	1

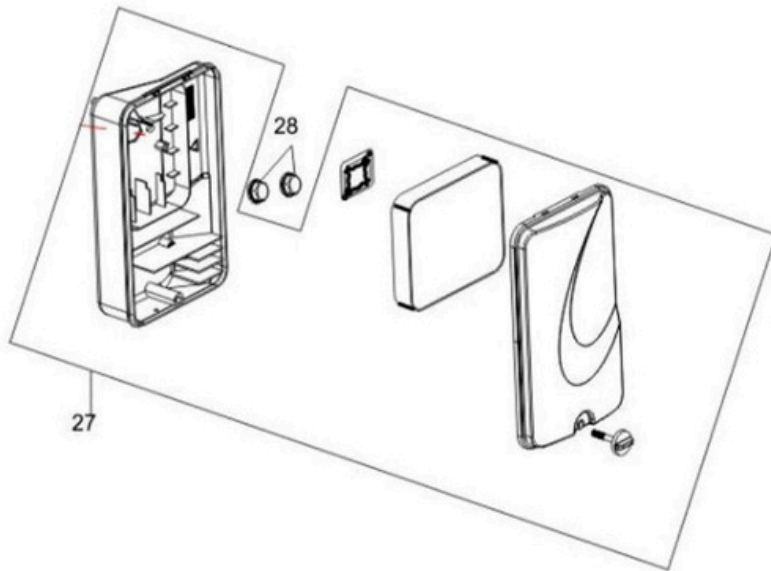

N°	PARTEN°	DESCRIPCIÓN	CANT
27	17100/2GF-3	air cleaner	1
28	GB/T6187.1	nut	2

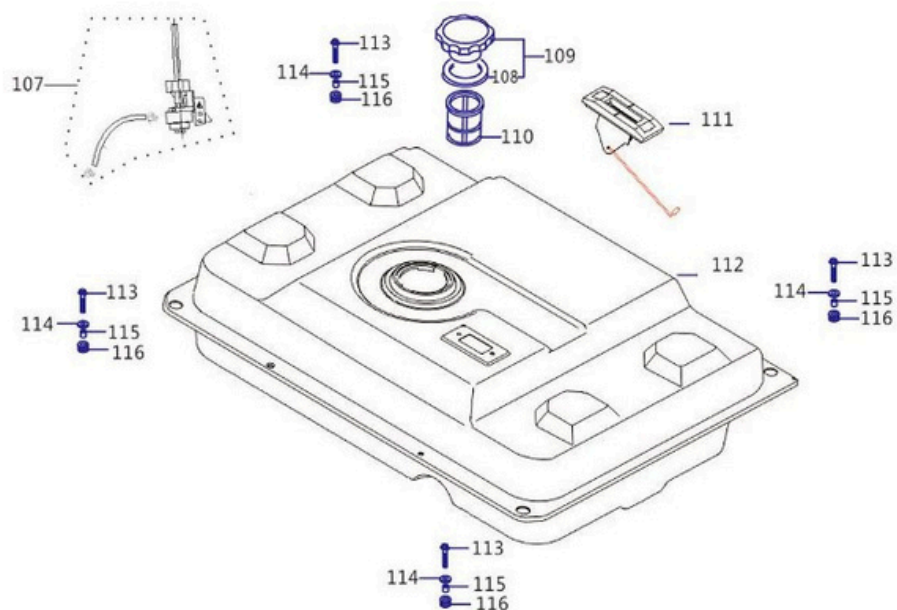

N°	PARTEN°	DESCRIPCIÓN	CANT
107	16640/2GF-3	switch assy	1
108	16414/168F	seal, fuel tank	1
109	16400/152F	fuel tank cap	1
110	16610/168F	filter cu	1
111	16560/2GF-3	Oil indicator	1
112	16510/2GF-3	fuel tank assy	1
113	GB/T16674	bolt	4
114	16546/2GF-3	washer, fuel tank	4
115	16914/2GF-3	bush	4
116	16911/2GF-3	cushion	4

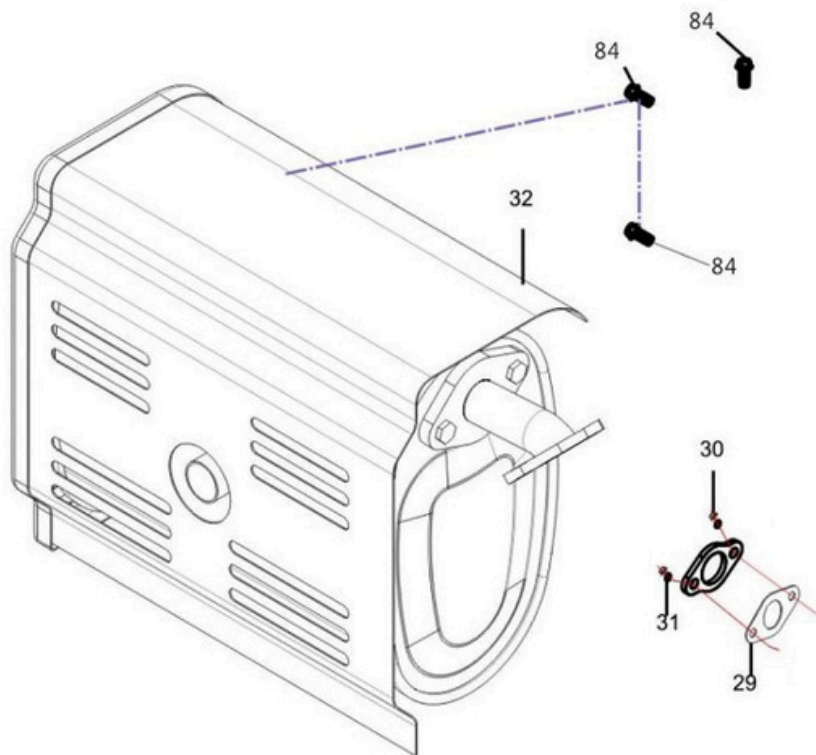

N°	PARTEN°	DESCRIPCIÓN	CANT
29	18215/168F	washer, exhaust valve	1
30	GB/T6170	nut	2
31	GB/T93	spring washer	2
32	18000/2.5GF-3I	muffler assy	1
84	GB/T5789	bolt	3

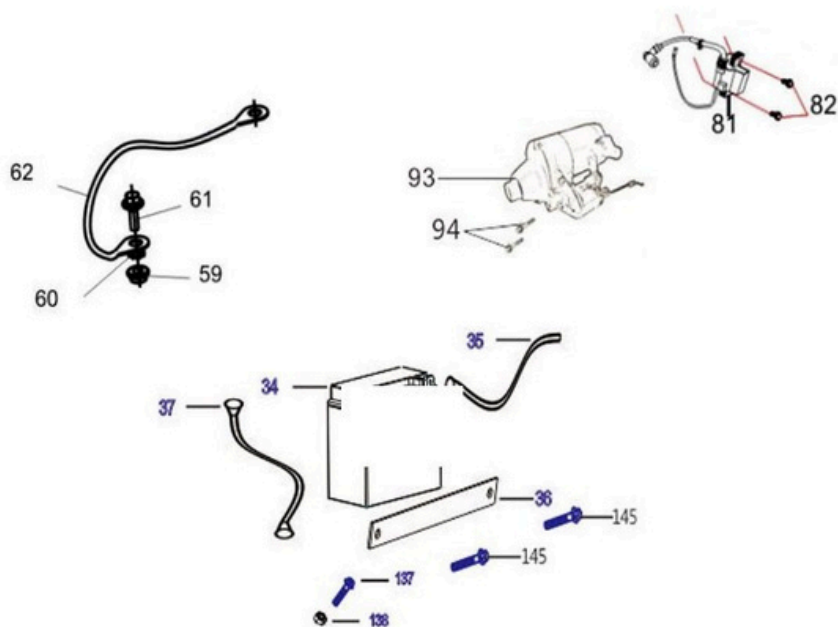

N°	PARTEN°	DESCRIPCIÓN	CANT
34	32432/2GF-4	battery	1
35	32434/2GF-4	battery wire	1
36	32433/2GF-3	press plate for battery	1
37	32434/2GF-4	battery wire (red)	1
59	GB/T6177.1	nut	1
60	31513/2GF-3	washer	1
61	GB/T5783	bolt	1
62	31222/2GF-3	earth terminal wire	1
81	27200/168F	ignition coil	1
82	GB/T5789	bolt	2
93	24100/168FD	starter motor	1
94	GB/T16674	bolt	2
145	GB/T16674	bolt	2

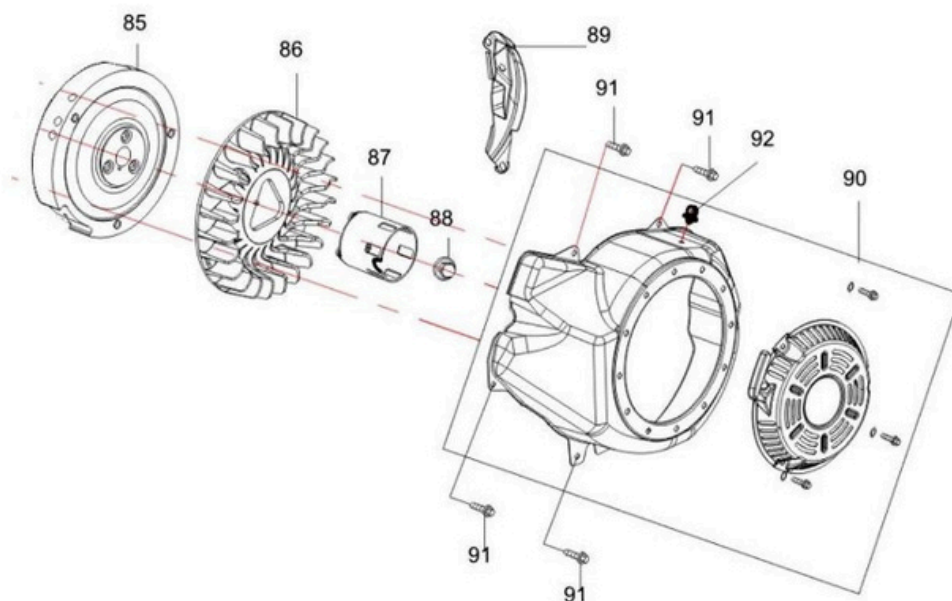

N°	PARTEN°	DESCRIPCIÓN	CANT
85	23300/168F	flywheel	1
86	19111/168F	fan, flywheel	1
87	23316/168F	starting cup	1
88	23317/168F	nut, flywheel	1
89	19300/168F	side plate	1
90	23100/2GF-3	recoil starter assy	1
91	GB/T5789	bolt	4
92	16628/173F	plastic pipe clamp	1

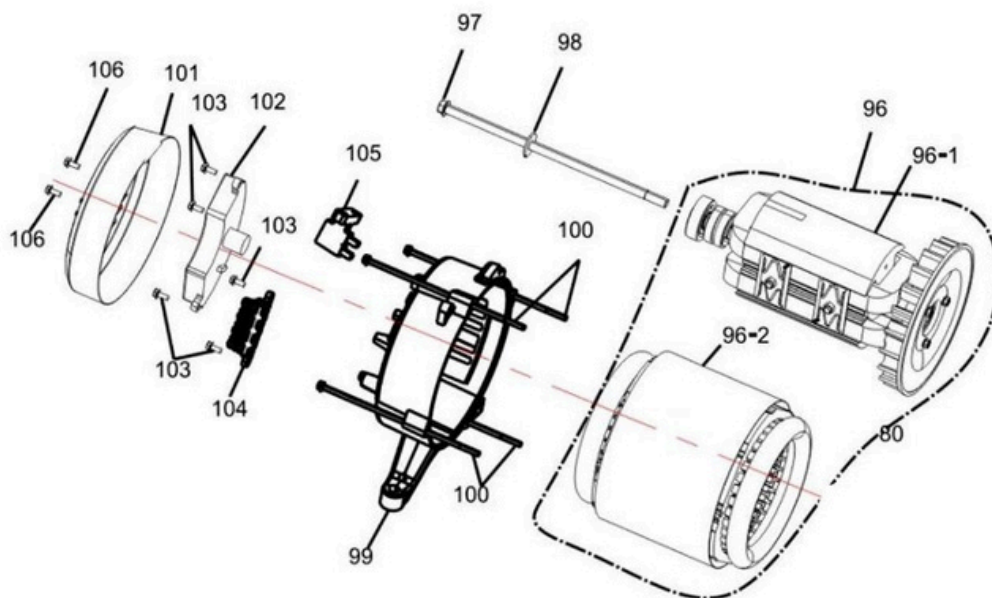

N°	PARTEN°	DESCRIPCIÓN	CANT
96	31100/2.5GF-3	Stator & rotor assy	1
97	31125/2.5GF-3	bolt	1
98	31126/2GF-3	washer	1
99	31151/2GF-3	basement	1
100	31112/2.5GF-3	bolt	4
101	31152/2GF-3	rear cover	1
102	31140/2GF-3	voltage regulating assy	1
103	GB/T5783	bolt	4
104	31154/2.8GF-3	conneting plate	1
105	31130/2GF-3	brush assy	1
106	GB/T5783	bolt	2

CONTROL PANEL

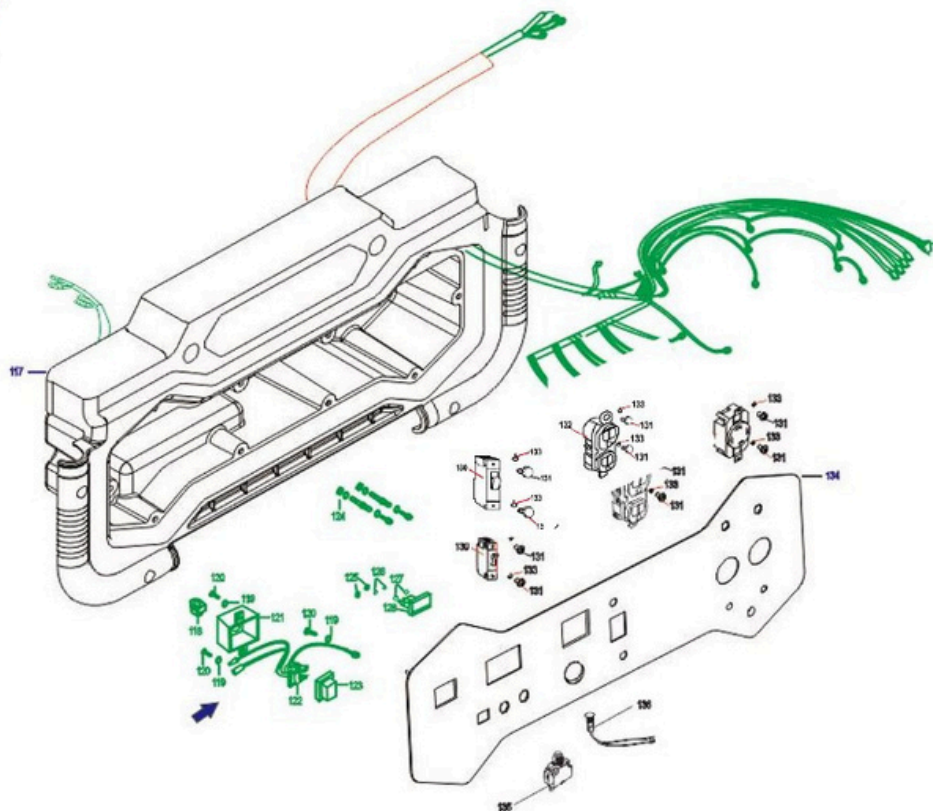

N°	PARTEN°	DESCRIPCIÓN	CANT
117	31251/2GF-3	rear cover for the control panel	1
118	31262/2GF-3	wire protect sleeve	1
119	GB93	spring washer	3
120	GB818	bolt	3
121	18314	dust cover	1
122	31225/2GF-4	switch	1
123	31228/2GF-4	waterproof cover for the switch	1
124	31231/2GF-4	wiring terminal	1
125	GB5787	nut	2
126	GB93	spring washer	2
127	GB97.1	washer	2
128	31226/5GF-4	voltmeter	1
129	31003/2.8GF-3	conneting terminal	1
130	31221/2.8GF-3	circle breaker	1
131	GB5787	bolt	6
132	31223/2GF-3	socket	1
133	GB93	Spring washer ϕ 3	10
134	32118/5GF-4	control panel	1
135	31218/2GF-3	AC protector	1
136	31215/2GF-3	indicator	1

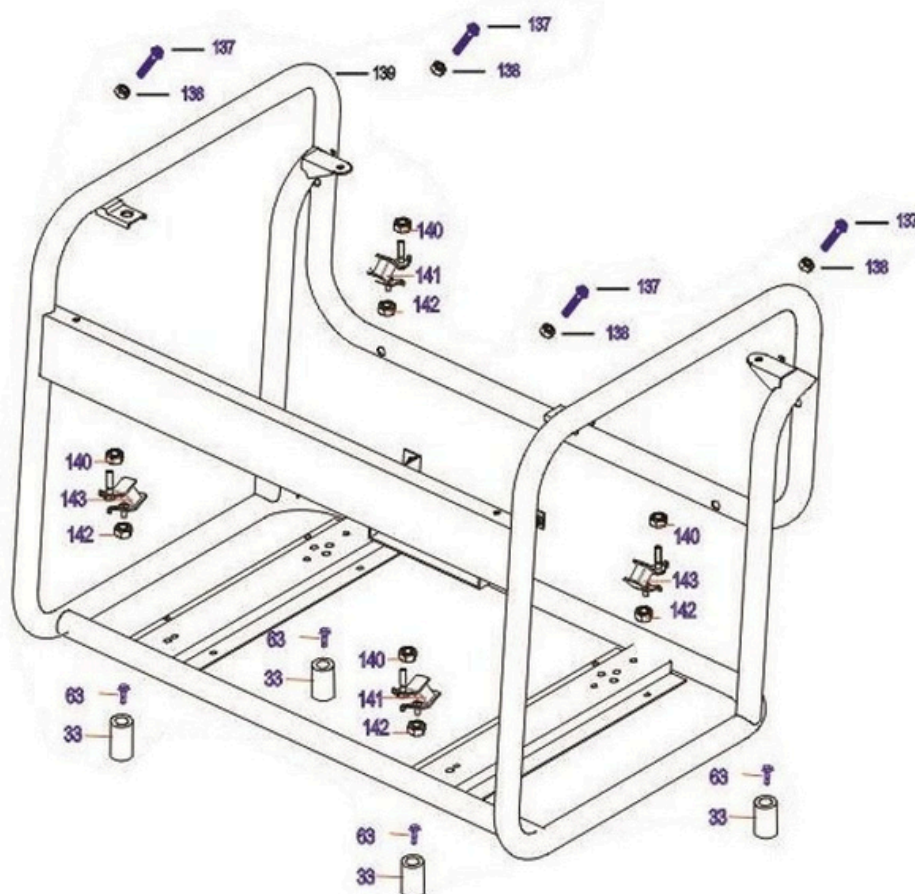

N°	PARTEN°	DESCRIPCIÓN	CANT
33	32413/2GF-3	cushion	4
63	GB/T5789	bolt	4
137	GB/T16674	bolt	4
138	GB/T6186.1	nut	4
139	32100/2.5GF-4	frame	1
140	GB/T6177.2	Nut	4
141	32420/2.8GF-3	cushion	2
142	GB/T6177.1	Nut	4
143	32450/2.8GF-3	cushion	2